

Features

- Multifunctional K-Band Testsystem
- CW VCO Transmitter 23...25GHz, 20dBm
- Received Signal Frequency Measurement
- Received Signal Power Meter
- Active Doppler Target Simulator
- Auxiliary IF Power Meter
- Standalone Operation or Hosted Operation
- USB and Serial Interface to Hostcomputer
- Extremely Compact and Rugged Construction

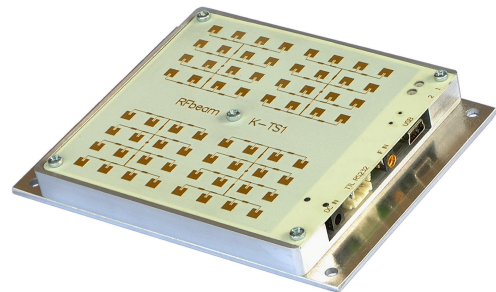

Applications

- Radarmodule Testsystems
- Production Final Inspection
- System Tuning and Adjustment
- Automatic Microwave Test Equipment

Description

K-TS1 is a fully integrated radarmodule test-system for K-band transmitters, receivers and transceivers. It consists of a digitally controlled synthesizer and transmitter, a selective receiver with power indicator and a synthetic doppler target simulator.

Its extremely compact construction makes it an ideal component for production and quality control systems. The "all-in-one" approach of K-TS1 simplifies geometrical adjustment of the

unit under test because it has to be targeted only once for all tests.

K-TS1 may be connected to a simple terminal software as well as to a high sophisticated measurement and analysis software.

Streaming or singleshot operation modes provide high flexibility.

With only a few keystrokes, you get high performance measurement results.

Functional Overview

Antenna and Connector Arrangement

Target Rx Antenna	Transmitter Antenna	LED 1	Operational Indicators
		LED 2	
		USB	Host Software (Terminal, LabVIEW etc)
Target Tx Antenna	Receiver Antenna	TTL I/O	Digital I/O Port
		RF In	RF power measurement for evaluating UUT system sensitivity
		DC In	Power supply 15 ... 24V

Fig. 1: Antenna and Connector Arrangement

K-TS1 Subsystems

The K-TS1 testsystem consists of 3 RF subsystems and 2 infrastructure subsystems:

- 1 **Target Simulator:** This subsystem simulates a moving object generating a stereo doppler signal. It receives the 24GHz carrier signal of a K-band doppler module and sends back a signal corresponding to an approaching target with a programmable frequency of -9999Hz to 9999Hz, where the sign simulates the direction of the target.
- 2 **Measuring System:** This subsystem may be used for measuring RF characteristics of K-band receivers, transmitters and transceivers. It sends a programmable, highly stable carrier frequency from 23...25GHz to a 4x4 path array antenna. At the same time, the RF generator is used as LO for the receiver. The receiver part allows measuring incoming RF power at a separate patch antenna. It also delivers signals for a high precision frequency determination of the incoming RF signal.
- 3 **AUX RF Power Meter:** This subsystems measures the input power arriving at an RF connector. It may be used e.g. for measuring the system sensitivity of external receivers, antenna test stands etc.
- 4 **Microcontroller System:** This subsystem controls all RF systems and builds the interface to hostsystems. It may be configured to operate K-TS1 as standalone system as well as under full host control. The TTL I/O is used to communicate with external hardware. The USB host interface assures a universal communication either with terminal emulation program or with high sophisticated, automated test stands.
- 5 **Power Supply:** K-TS1 may be operated from simple 15V..24VDC adaptors.

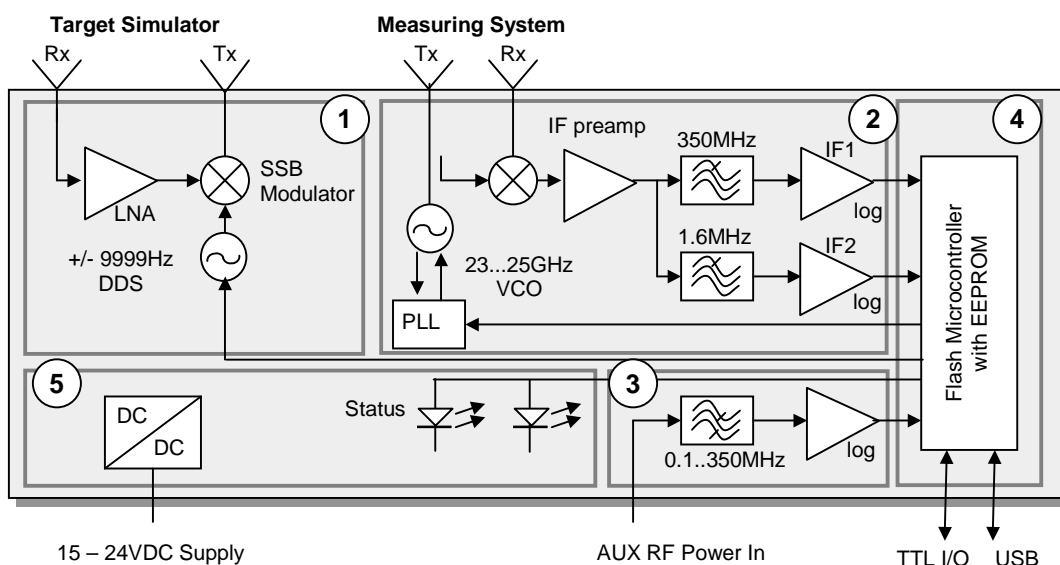

Fig. 2: Block Diagram