

K-MC3 RADAR TRANSCEIVER

Product Information

Features

- 24 GHz short range transceiver
- Beam aperture **25°/7°**
- Electrically compatible to RFbeam K-MC2
- 180MHz sweep FM input
- High sensitivity, integrated RF/IF amplifier
- Dual 54 patch narrow beam antenna
- Buffered I/Q IF outputs
- Additional DC IF outputs
- RSW Rapid Sleep Wakeup
- Extremely compact: 105x85x5 mm³ construction

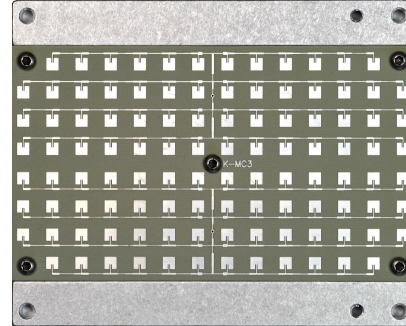

Applications

- Traffic supervision and counting
- Object speed measurement systems
- Ranging and distance detection
- Industrial sensors

Description

K-MC3 is a 108 patch doppler module with an asymmetrical narrow beam for long distance sensors. It is ideally suited for traffic supervision.

This module includes a RF low noise amplifier and two IF preamplifiers for both I and Q channels. The need for external analogue electronics will be significantly reduced by this feature. For special signal condition applications, an additional buffered Mixer DC output is provided. This greatly improves flexibility in FSK ranging applications.

The unique "RSW" Rapid Sleep Wakeup function with <4us wakeup time makes this module ideal for battery operated equipment. Typical duty cycle in RWS mode may be < 5% with full movement detection capability by sampling the IF signals.

An extremely slim construction with only 6mm depth gives you maximum flexibility in your equipment design.

Powerful starterkits with signal conditioning and visualization are also available. (see www.rfbeam.ch Download Section)

Blockdiagram

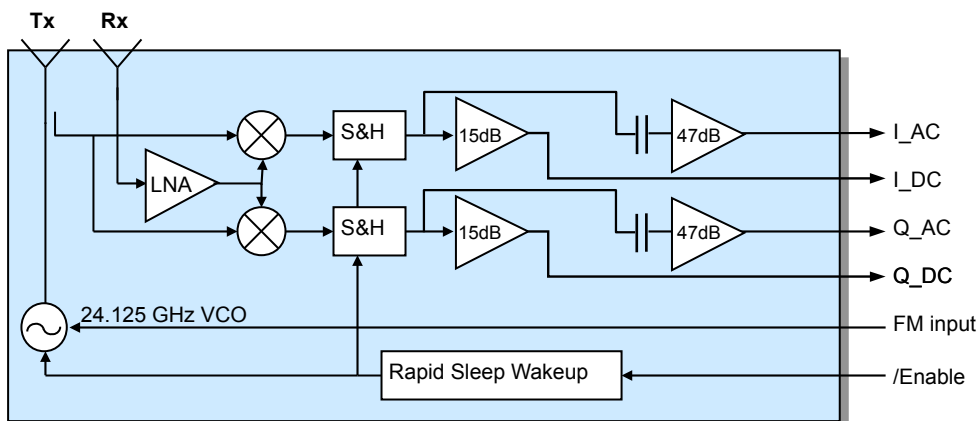

Fig. 1: K-MC3 Blockdiagram

K-MC3 RADAR TRANSCEIVER

Product Information

Characteristics

Parameter	Conditions / Notes	Symbol	Min	Typ	Max	Unit
Operating conditions						
Supply voltage		V_{cc}	4.75	5.0	5.25	V
Supply current	Module enabled (Pin 1 = V_{IL})	I_{cc}		70	100	mA
	Module RSW mode (Pin 1 = V_{IH})			7	10	mA
VCO input voltage		U_{vco}	1		10	V
Power down/Enable						
Module power down	Input tied high with pullup 10k	V_{IH}	$V_{cc}-0.7$		$V_{cc}+0.3$	V
Module enable		V_{IL}	-0.2		2	V
Minimum enable time	Sample&Hold capacitor charged	t_{on}	4			μ s
Maximum hold time	S&H error <10%	t_{off}			2	ms
Transmitter						
Transmitter frequency	$U_{vco}=5V, T_{amb}=-20^{\circ}C \dots +60^{\circ}C$	f_{TX}	24.050	24.150	24.250	GHz
Frequency drift vs temp.	$V_{cc}=5.0V, -20^{\circ}C \dots +60^{\circ}C$ <small>Note 1</small>	Δf_{TX}		-1.0		MHz/ $^{\circ}C$
Frequency tuning range		Δf_{vco}		180		MHz
VCO sensitivity		S_{vco}		18		MHz/V
VCO Modulation Bandwidth	$\Delta f=20MHz$	B_{vco}		3		MHz
Output power	EIRP	P_{TX}	+16	+19	+20	dBm
Receiver						
Receiver sensitivity	$f_{IF}=500Hz, B=1kHz, S/N=6dB$	P_{RX}		-126		dBm
Overall sensitivity	$f_{IF}=500Hz, B=1kHz, S/N=6dB$	D_{system}		-145		dBc
IF output						
IF output impedance	_AC outputs	R_{IF_AC}		100		Ω
	DC outputs	R{IF_DC}		100		Ω
IF frequency range	-3dB Bandwidth (_AC outputs)	f_{IF_AC}	40		15k	Hz
	-3dB Bandwidth (_DC outputs)	f_{IF_DC}	0		500	kHz
IF noise voltage	$f_{IF}=500Hz$	$U_{IFnoise}$		22		μ V/ \sqrt{Hz}
	$f_{IF}=500Hz$	$U_{IFnoise}$		-93		dBV/Hz
Antenna						
Horizontal -3dB beamwidth	E-Plane	W_{φ}		7		$^{\circ}$
Vertical -3dB beamwidth	H-Plane	W_{θ}		25		$^{\circ}$
Horiz. sidelobe suppression		D_{φ}		-20		dB
Vert. sidelobe suppression		D_{θ}		-18		dB
Body						
Outline Dimensions	connector left unconnected			105x85x5		mm ³
Weight				102		g
Connector	Module side: AMP X-338069-8			8		pins

K-MC3 RADAR TRANSCEIVER

Product Information

Parameter	Conditions / Notes	Symbol	Min	Typ	Max	Unit
Operating conditions						
Supply voltage		V_{cc}	4.75	5.0	5.25	V
Supply current	Module enabled (Pin 1 = V_{IL})	I_{cc}		70	100	mA
	Module RSW mode (Pin 1 = V_{IH})			7	10	mA
VCO input voltage		U_{VCO}	1		10	V
Power down/Enable						
Module power down	Input tied high with pullup 10k	V_{IH}	$V_{cc}-0.7$		$V_{cc}+0.3$	V
Module enable		V_{IL}	-0.2		2	V
Minimum enable time	Sample&Hold capacitor charged	t_{on}	4			μ s
Maximum hold time	S&H error <10%	t_{off}			2	ms
Transmitter						
Transmitter frequency	$U_{VCO}=5V, T_{amb}=-20^{\circ}C \dots +60^{\circ}C$	f_{TX}	24.050	24.150	24.250	GHz
Frequency drift vs temp.	$V_{cc}=5.0V, -20^{\circ}C \dots +60^{\circ}C$ ^{Note 1}	Δf_{TX}		-1.0		MHz/ $^{\circ}C$
Frequency tuning range		Δf_{VCO}		180		MHz
VCO sensitivity		S_{VCO}		18		MHz/V
VCO Modulation Bandwidth	$\Delta f=20MHz$	B_{VCO}		3		MHz
Output power	EIRP	P_{TX}	+16	+19	+20	dBm
Receiver						
Receiver sensitivity	$f_{IF}=500Hz, B=1kHz, S/N=6dB$	P_{RX}		-126		dBm
Overall sensitivity	$f_{IF}=500Hz, B=1kHz, S/N=6dB$	D_{system}		-145		dBc
IF output						
IF output impedance	_AC outputs	R_{IF_AC}		100		Ω
	DC outputs	R{IF_DC}		100		Ω
IF frequency range	-3dB Bandwidth (_AC outputs)	f_{IF_AC}	40		15k	Hz
	-3dB Bandwidth (_DC outputs)	f_{IF_DC}	0		500	kHz
IF noise voltage	$f_{IF}=500Hz$	$U_{IFnoise}$		22		μ V/ \sqrt{Hz}
	$f_{IF}=500Hz$	$U_{IFnoise}$		-93		dBV/ \sqrt{Hz}
Antenna						
Horizontal -3dB beamwidth	E-Plane	W_{θ}		7		$^{\circ}$
Vertical -3dB beamwidth	H-Plane	W_{ϕ}		25		$^{\circ}$
Horiz. sidelobe suppression		D_{θ}		-20		dB
Vert. sidelobe suppression		D_{ϕ}		-18		dB
Body						
Outline Dimensions	connector left unconnected			105x85x5		mm ³
Weight				102		g
Connector	Module side: AMP X-338069-8			8		pins

Note 1 Transmit frequency stays within 24.050 to 24.250GHz over the specified temperature range if VCO pin is left open

Note 2 Theoretical value, given by design